

Warning Note:
 If the US IC RT8258 is used, the components D20 and R13 NOT install!!!
 If replace US on IC LMR12010, LMR12007 or MCP16301, you should install components D20 and R13

Note:
 If L1 = 220nH 1.2A, Iout=16mA, efficiency 85%, R21 = 100mOhm
 If L1 = 100nH 2.5A, Iout=40mA, efficiency 77%, R21 = 50mOhm

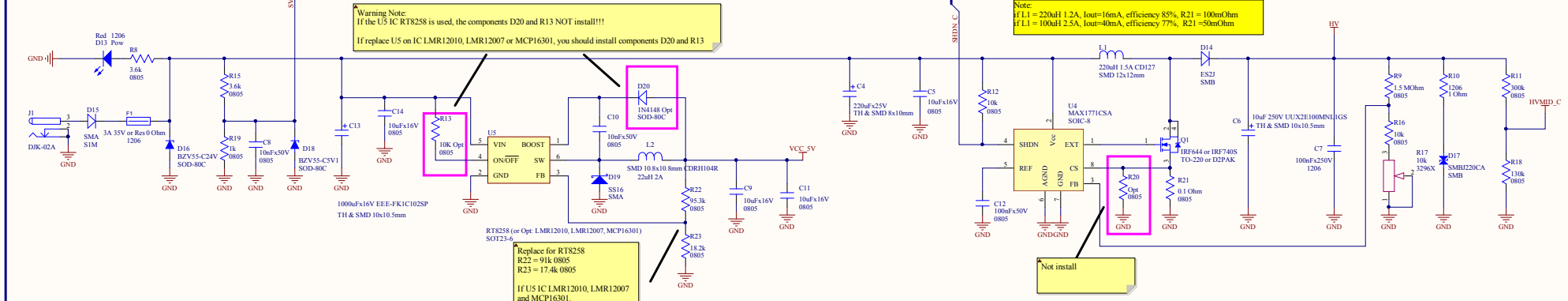

Replace for RT8258
 R22 = 91k 0805
 R23 = 17.4k 0805

If US IC LMR12010, LMR12007 and MCP16301
 R22 = 52.3k
 R23 = 10k

